

GEAR MOTOR



GEAR MOTOR

臥式減速馬達 FOOT MOUNT TYPES GEAR MOTOR

立式減速馬達 V CASING TYPES GEAR MOTOR

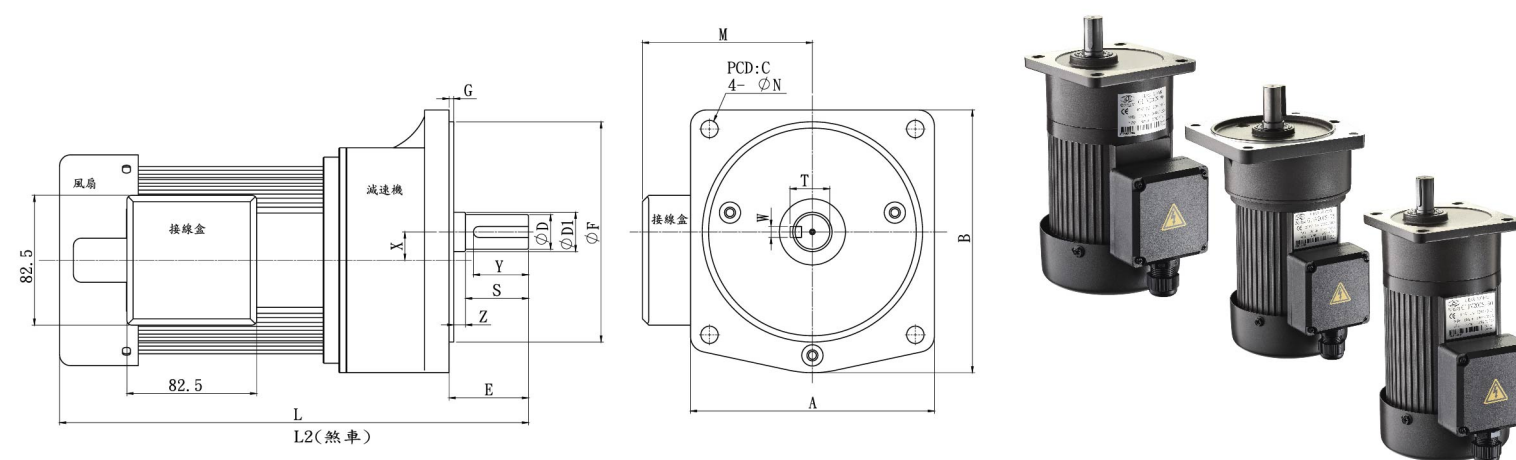
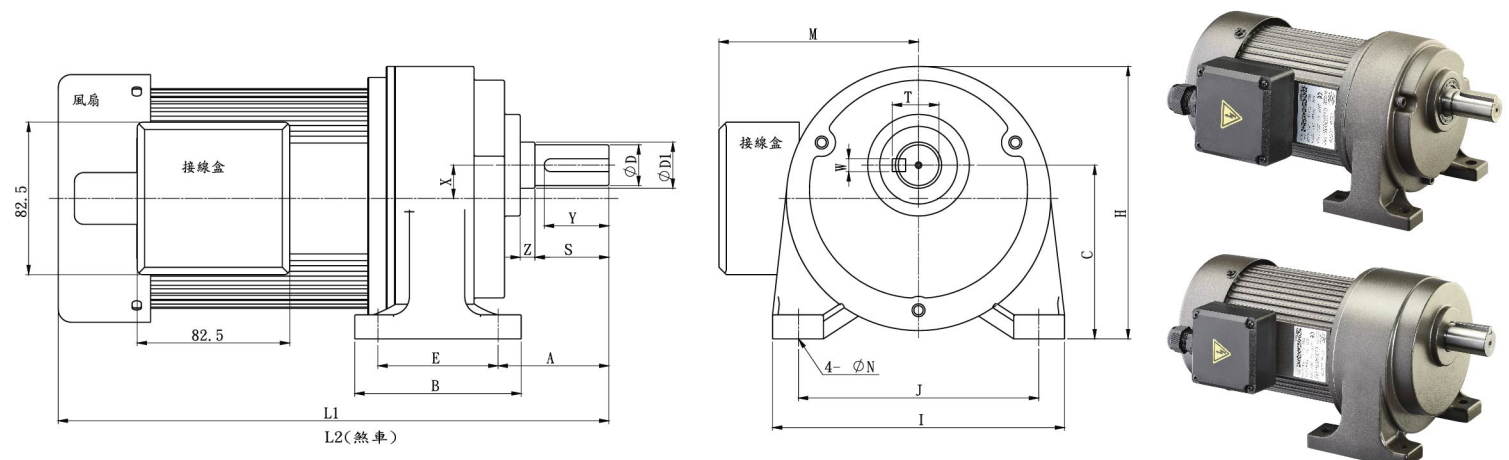

品名的定義 MEANING OF THE PRODUCT NUMBER

G12	H	100	S	M	100
框號 FRAME SIZE	型式 TYPE	出力 OUTPUT	電壓極數 VOLT/POLE	其它附件 ACCESSORY	減速比 RATIO
G12 G13	H:臥式 FOOT MOUNT TYPE	100:100W 200:200W 400:400W 750:750W	A:1Ø 110V 4P C:1Ø 220V 4P G:1Ø 110/220V 4P S:3Ø 220/380V 4P	M: 電磁斷電煞車 ELECTRO MAGNETIC BRAKE P: 溫度保護 THERMO SWITCH MH: 手釋放煞車 ELECTRO MAGNETIC BRAKE WITH MANUAL RELEASE HANDLE	100:1/100 1:3~1:180

品名的定義 MEANING OF THE PRODUCT NUMBER

G12	V	100	S	M	100
框號 FRAME SIZE	型式 TYPE	出力 OUTPUT	電壓極數 VOLT/POLE	其它附件 ACCESSORY	減速比 RATIO
G11 G12 G13	V:立式 V CASING TYPE	100:100W 200:200W 400:400W 750:750W	A:1Ø 110V 4P C:1Ø 220V 4P G:1Ø 110/220V 4P S:3Ø 220/380V 4P	M: 電磁斷電煞車 ELECTRO MAGNETIC BRAKE P: 溫度保護 THERMO SWITCH MH: 手釋放煞車 ELECTRO MAGNETIC BRAKE WITH MANUAL RELEASE HANDLE	100:1/100 1:3~1:180

尺寸表 Dimension (mm)

馬達容量 MOTOR CAPACITY	型號 TYPE NO.	減速比 GEAR RATIO	A	B	C	E	H	I	J	L1	L2	M	N	X	出力軸 OUTPUT SHAFT						
															D	D1	S	T	W	Y	Z
100W 1/8HP*4P	11	1/3~1/90	50.5	65	85	40	128	135	110	251.5	296.5	108	9	18	18	20	32	20	5	28	1
	11	1/3~1/40	50.5	65	85	40	128	135	110	276.5	321.5	108	9	18	18	20	32	20	5	28	1
200W 1/4HP*4P	11	1/50~1/90	60	90	94	65	147.5	158	130	298	343	108	11	18	22	25	40	25	7	35	8
	12	1/50~1/90																			
	12	1/75~1/165																			
400W 1/2HP*4P	13	1/100~1/180	68	120	115	90	175	180	140	322.5	367.5	108	11	25	28	30	45	31	7	40	2.5
	12	1/3~1/30	60	90	94	65	147.5	158	130	324	363	115.5	11	18	22	25	40	25	7	35	8
	12	1/50~1/90																			
	13	1/50~1/90																			
13	1/100~1/180																				
750W 1HP*4P	13	1/3~1/30	68	120	115	90	175	180	140	352.5	394.5	124.5	11	25	28	30	45	31	7	40	2.5
	13	1/50~1/90																			

尺寸表 Dimension (mm)

馬達容量 MOTOR CAPACITY	型號 TYPE NO.	減速比 GEAR RATIO	A	B	C	E	F	G	L	L2	M	N	X	Y	出力軸 OUTPUT SHAFT						
															D	D1	S	T	W	Z	
100W 1/8HP*4P	11	1/3~1/90	122	122	138	42			251.5	296.5	108	9*11	18	28	18	20	32	20	5	3	
	11	1/3~1/40	122	122	138	42			276.5	321.5	108	9*11	18	28	18	20	32	20	5	3	
200W 1/4HP*4P	11	1/50~1/90	155	167	185	50.5	140	3	298	343	108	11	18	35	22	25	40	25	7	7.5	
	12	1/50~1/90																			
	12	1/75~1/165																			
	13	1/100~1/180																			
400W 1/2HP*4P	12	1/3~1/30	180	200	220	50	170	3	322.5	367.5	108	11	25	40	28	30	45	31	7	2	
	12	1/50~1/90																			
	13	1/50~1/90																			
	13	1/100~1/180																			
750W 1HP*4P	13	1/3~1/30	180	200	220	50	170	3	352.5	394.5	124.5	11	25	40	28	30	45	31	7	2	
	13	1/50~1/90																			